



O P E R A T I N G  
M A N U A L

**slee** solutions  
for  
pathology

CRYOSTAT  
**MNT**

HIGH-END CRYOSTAT

DESIGN &  
MANUFACTURING  
MADE IN GERMANY



# CONTENTS

<b>1. INTENDED USE</b>	.....	<b>4</b>
<b>2. SYMBOLS</b>	.....	<b>4</b>
<b>3. SAFETY NOTES</b>	.....	<b>4</b>
<b>4. COMPONENTS</b>	.....	<b>9</b>
<b>5. SPECIFICATIONS</b>	.....	<b>10</b>
<b>6. UNPACKING AND INSTALLATION</b>	.....	<b>12</b>
<b>7. INITIAL OPERATION</b>	.....	<b>16</b>
<b>8. OPERATION OF MICROTOME</b>	.....	<b>22</b>
<b>9. OPERATION OF CRYOSTAT</b>	.....	<b>35</b>
<b>10. CLEANING AND MAINTENANCE</b>	.....	<b>40</b>
<b>11. SERVICE</b>	.....	<b>42</b>
<b>12. OPTIONAL ACCESSORIES</b>	.....	<b>43</b>
<b>13. WARRANTY</b>	.....	<b>45</b>
<b>14. DISPOSAL</b>	.....	<b>45</b>

## 1. INTENDED USE

The floor standing open top cryostat MNT is intended for rapid freezing and cutting thin sections of frozen specimens for professional use in routine and research laboratories in the fields of biology, medicine and industry.

The system of knife advance operates very reliable from 0.5 to 100 µm with trimming function up to 750 µm. The quality of cutting of this microtome is increased by the automatic retraction during the upstroke of the specimen, which avoids rubbing on the disposable blades or microtome knives. This stops rapid deterioration of the disposable blade or microtome knife.

## 2. SYMBOLS



Dangers, warnings and cautions are marked by this symbol



Special instructions regarding the operation of the instrument are marked by this symbol



Mechanical components that can lead to injuries during operation are marked with this symbol.



Symbol “flammable freezing sprays are prohibited”

## 3. SAFETY NOTES

The Slee open top cryostat MNT is provided with the following safety features:

**Hand wheel stop**

**Finger protection for Knife- and blade-holder**

**Emergency stop switch**

MNT
●
●
●

The institution which owns the unit and the persons working with the unit, servicing or repairing it have the responsibility for a hazard-free use.

### 3.1 Hand wheel stop

Always use the finger protection with the knife-/blade holder and put hand wheel in stop position

- before working with the knife or specimen
- before changing the specimen
- during break time

The hand wheel can be stopped in any position. For this purpose move the stop lever towards the centre.

For releasing the stop please turn the lever towards the outside again.

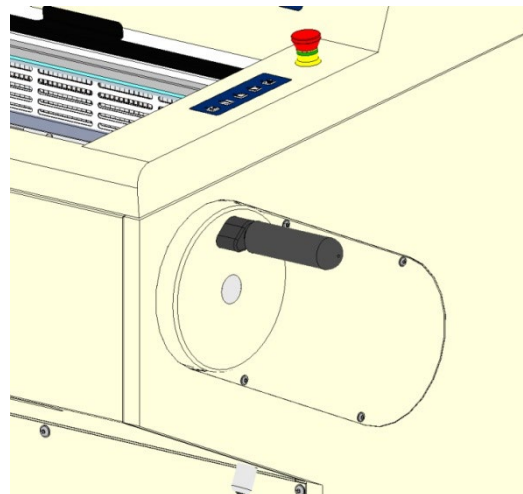

Hand wheel stop released. Movement.

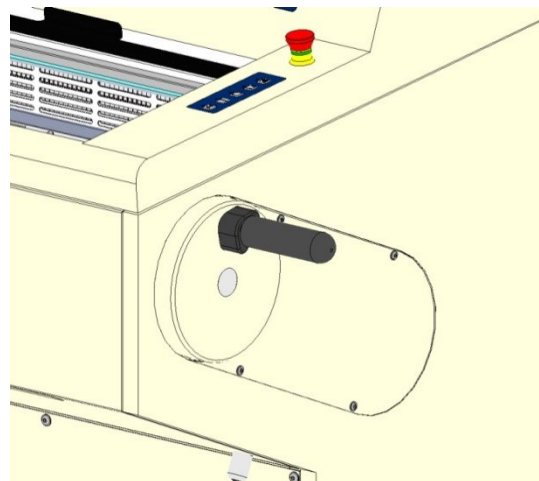

Hand wheel stop activated. No movement.

### 3.2 FINGER PROTECTION

Use the finger protection always

- Before you start any work with the knife or specimen
- Before changing the specimen
- During work break

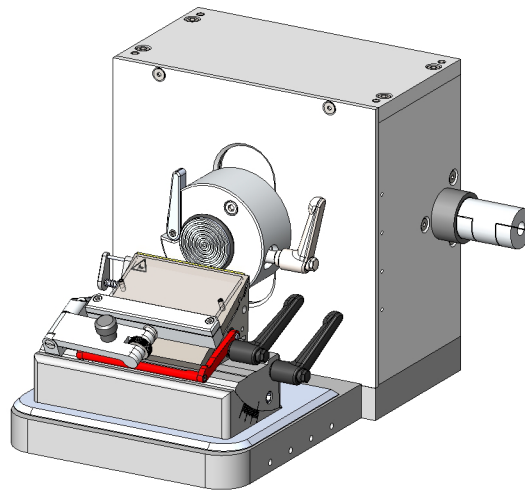

Finger protection released.

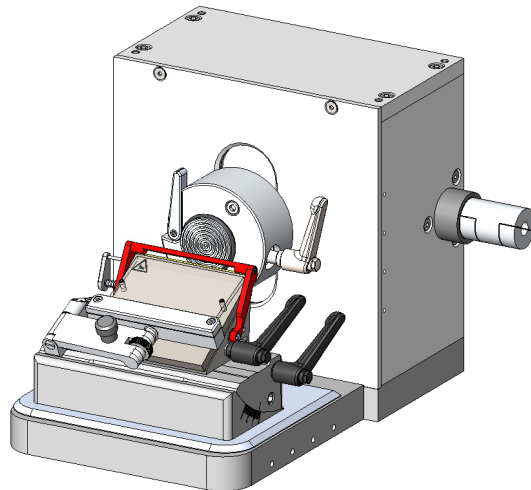

Finger protection activated.

### 3.3 ELECTRICAL POWER CONNECTION

Do not use any extension lead.



Make sure that electric power is constant. Make sure that electric power is constant. Please note that the compressor requires a start-up current between 25 and 35 A. The electric circuit at the installation site must be inspected by an electrical engineer to ensure that it meets the requirements for a smooth operation of the instrument.

- This should be examined during installation of the unit by a competent person
- Use a dedicated fuse for the unit
- Do not connect another unit to the same power circuit.
- Before turning on the instrument, check if the voltage of the mains supply is identical with the name plate of the unit

### 3.4 WORKING WITH KNIVES AND DISPOSABLE BLADES

Microtome knives and disposable blades have extremely sharp edges and this can lead to injuries.

Please be extremely careful when handling microtome knives and disposable blades.



Do not place microtome knives or disposable blades at unsecured areas.

Never position microtome knives or disposable blades with the sharp edge pointing upwards.

Store blades in a covered container. Use a container that has guides to hold the blades rigid.

Never try to catch a falling microtome knife.

Always insert the specimen first and then the microtome knife or disposable blade.

To avoid compression or knife marks, ensure that the blade is clean.

### 3.5 EMERGENCY SWITCH

By pressing the red emergency switch an emergency stop is activated. The cutting motor stops immediately.

For deactivating the emergency stop it has to be turned, then it moves automatically back into the original position.

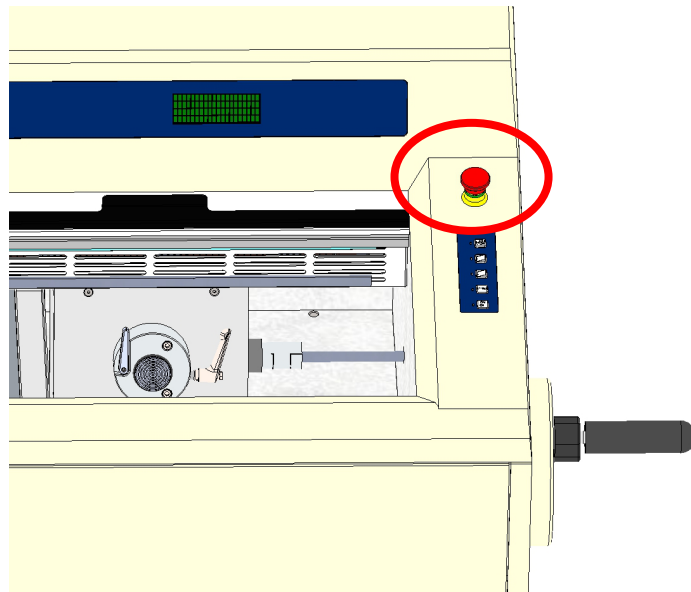

Emergency stop switch.

### 3.6 MOTORIZED OPERATION

For switching off the motor please always use the hand or foot switch. Do never simply set the speed to 0.



## 4. COMPONENTS

The Slee open top cryostat MNT is provided with the following standard components:

**Basic unit with refrigeration system**

**Fully automatic rotary microtome**

**Operation manual**

**Specimen holder**

(5x Ø 22mm; 5x Ø 35 mm)

*clear-cut* **Brush**

**Anti-roll plate**

Ready to use

**1x Bottle cryostat low temperature oil**

**4x 125 ml CryoGlue embedding medium**

**1 Box of disposable blades (50 pcs.) or 1 steel knife (16 cm C-profile)**

**Set of Allen keys**

MNT
●
●
●
●
●
●
●
●
●
●

## 5. SPECIFICATIONS

### General

Nominal power	230 V AC +-10%	115 V AC +-10%
Nominal frequency	50 / 60 Hz	60 Hz
Power draw	860 VA <small>chamber</small> 1.380 VA <small>chamber and object cooling</small>	860 VA <small>chamber</small> 1.380 VA <small>chamber and object cooling</small>
Max. current for 5 sec	17 A	35 A
Protective class	I	I
Fuses	2x T 10 A	2x T 20 A
Pollution class	2	2
Overcurrent protective class	II	II
Max. heat energy	860 J/s <small>Chamber</small> 1.380 J/s <small>chamber and object cooling</small>	860 J/s <small>Chamber</small> 1.380 J/s <small>chamber and object cooling</small>
Operating temperature range	+10 to +35 °C	
Operating humidity	max. rel. 80 % non-condensing	
Storage temperature range	+5 to +55 °C	
Storage humidity	max. rel. 80 % non-condensing	

### Cryochamber

Temperature range	0°C to -35°C, selectable in 1 K steps, Environment: 20°C	
Cooling power	636 W	514 W
Switch off pressure	25 bar	25 bar
Current	3,69 A	6,45 A
Cooling gas	R 404 A, 320 g	R 404 A, 320 g

### Object cooling (optional)

Temperature range	0°C to -50°C, selectable in 1 K steps, Environment: 20°C	
Cooling power	193 W	278 W
Switch off pressure	25 bar	25 bar
Current	1,69 A	3,06 A
Cooling gas	R 449 A, 50 g	R 449 A, 50 g

## Optional specimen cooling

Temperature range	0°C to -45 °C +-3 K	
Cooling power	193 W	278 W
Switch off pressure	25 bar	25 bar
Current	1,69 A	3,06 A
Cooling gas	R 449 A, 50 g	R 449 A, 50 g

## Chamber defrost

Automatic defrost	hot gas defrost, time selectable, 1-3 times per day or manual defrost on request
Automatic stop	at -5 °C chamber temperature

## Freezing bar

Minimum temperature	10 K lower than chamber temperature
Number of positions	24 (Standard version) resp. 21 + 2 (version with quick freeze places)
Quick freeze positions	2 (optional), to -55 °C (Peltier cooling)

## Microtome

Type	rotary microtome, incapsulated, motorized advance, motorized cutting
Thickness range	0.5 – 100 µm
Thickness settings	0 – 2 µm in 0.5 µm steps 2 – 20 µm in 1 µm steps 20 – 50 µm in 2 µm steps 50 – 100 µm in 5 µm steps
Horizontal movement	28 mm
Vertical movement	58 mm
Retraction during upward stroke	0 – 200 µm, free selectable (defined steps)
Trimming	0,5 – 750 µm, free selectable (defined steps)
Specimen orientation	8° (x and y axes), 360° (z axes) Zero point detent x and y axis
Motor speed	3 to 300 mm/s

## Cryostat

Dimensions (L x W x H)	750 mm x 760 mm x 1110 mm
Weight (without accessories)	135 kg (without object cooling) 154 kg (with object cooling)

\*All temperature specifications refer to an ambient temperature of + 20 ° C and a relative humidity of 60%

## 6. UNPACKING AND INSTALLATION

### 6.1 UNPACKING THE INSTRUMENT

In standard design you will receive the unit in a cardboard box standing on a wooden pallet. The unit is equipped with four castors and two feet, adjustable in height in the front.



When the instrument is delivered, check the tilt indicators and shock watches on the packaging. If tilt indicators are activated, the shipment was transported laying flat, was tilted at too great an angle or fell over during transport. If the shock watches are activated, the instrument fell over during transport. Note this on the shipping documents and check the shipment for possible damage.

Open the cardboard box from the top and remove the accessories together with the supporting foams. Then remove the cardboard box.

Remove the screws on the two fixation brackets that hold the instrument on the wooden pallet.

Swing out the ramp on which the instrument can be rolled down off the transport pallet. To ensure a safe transport two (2) people are required.

Carefully lift the instrument slightly while rolling it down the ramp from the pallet and push the instrument to the installation location on the castors.

Extend the two front feet to stabilize the cryostat in its position by turning the supporting screws counter clockwise.

For repacking use the original cases. Keep the packing material.

## 6.2 INSTALLATION SITE REQUIREMENTS

The site for installation should meet the following requirements:

- A maximum ambient temperature of 22 °C
- No direct sunlight into the cooling chamber
- Mains power supply within 3 m
- No air circulation (for example by air conditioning)
- Instrument may only be used inside rooms
- The mains supply should not be connected in series with other devices, such as multiple sockets - a separate circuit should be provided
- Handwheel must be reached easily
- Relative humidity lower than 60%
- A minimum distance between wall and rear of the instrument of 10-20 cm should be guaranteed



■ High room temperatures and high humidity influence the cooling capacity of the instrument and will lead to ice forming inside the instrument.

## 6.3 INSTALLATION

For opening the chamber push the window to the top.

Remove the transport security underneath the specimen holder.

After installation, wait at least 4 hours before switching the instrument on. Failure to comply may result in severe damage to the instrument.

<p>The device is delivered with a defrosting water collecting container, which must be installed before the device is put into operation.</p> <p>First mount the metal bracket for the defrosting water container on the right side of the device. Loosen the screws and hang the bracket in the screws. Now tighten the screws.</p>	 <p>Installation of the metal bracket for the defrost water collector.</p>
<p>Place the defrosting water container in the metal holder and connect the defrosting water pipe and the level sensor to the device.</p>	 <p>Connection of the defrost water pipe and the level sensor to the device.</p>



It is necessary to install the laterally defrost container, otherwise there may be icing on the evaporator! We recommend filling the container with 500 ml disinfectant before initial operation.

After installation, wait at least 4 hours before switching on the instrument. Failure to comply may result in severe damage to the instrument.

## 6.4 COLLAPSIBLE HANDWHEEL LEVER

The instrument is delivered with a ready to use hand wheel lever that is folded away for transport reasons.

- Before you start any work unfold the hand wheel lever by simply pulling the lever into a horizontal position.
- For folding the lever back, pull the horizontally orientated lever and fold it away.

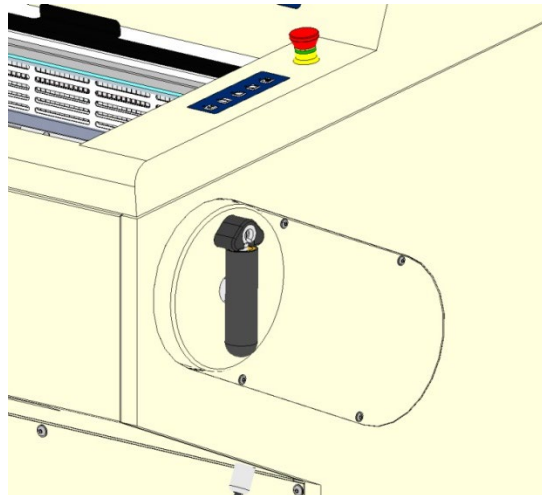

Hand wheel lever in folded position.

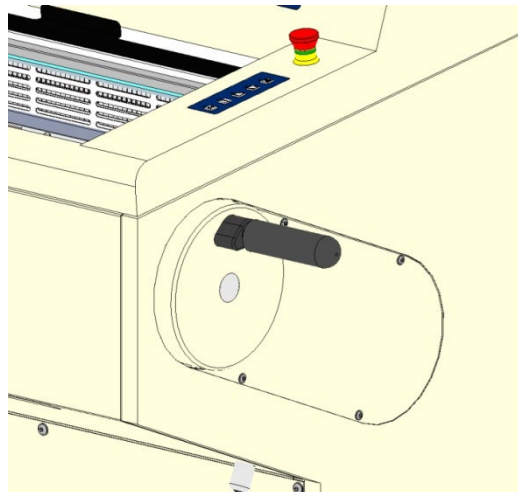

Hand wheel lever unfolded.

## 7. INITIAL OPERATION

### 7.1 MAIN DISPLAY

The main display will show the day and time, the cutting thickness, the trimming thickness, the current chamber temperature, the target chamber temperature, the status of the quick-freeze unit (optional) and the total electronic status of the instrument and a cutting counter (optional).

TUE 13:05:05	
CUT: 7 $\mu\text{m}$	Trim: 19 $\mu\text{m}$
Cha: -20 °C (-22)	QF: 0
Status:OK	0000

### 7.2 CONTROL PANEL

Software settings and motor operation can be operated with the control panel on the left and right side of the instrument.

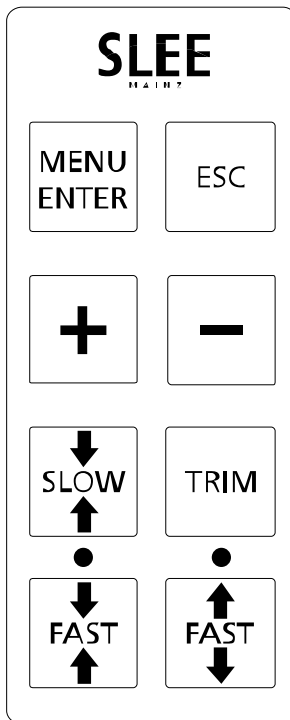

Software and horizontal motor control panel on left top side of MNT.

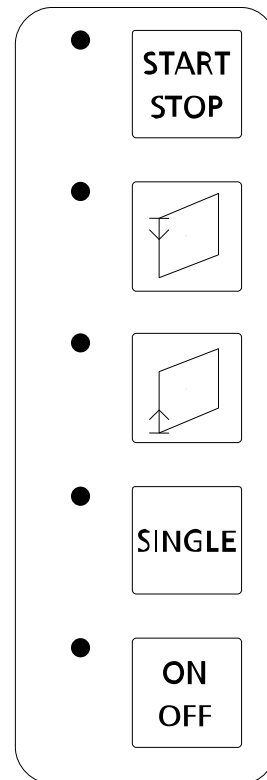

Cutting motor control panel on right top side of MNT.



## 7.3 SOFTWARE SETTINGS

Press  to open the Settings menu.

>	Chamber temp	-20 °C
	Quickfreeze	Off
	UV disinfection	
	Light	Auto

To move further down in the main menu list, press .



	Retraction	5 µm
	Start defrost	
	Contrast	
>	TIME	TUE 13:05:05

To move further up in the main menu list, press .

>	Light	Auto
	Light duration	10 m
	Chamber incr	-15 °C
	Retraction	5 µm

To change values, select a setting.

Press  to open the setting.

Change entries by pressing  or .

Store new settings by pressing .

	Light duration	10 m
>	Chamber incr	-15 °C
	Retraction	5 µm
	Start defrost	

Press  to return to the main menu.

TUE 13:05:05	
CUT: 7 µm	Trim: 19µm
Cha: 22 °C (25)	QF: 0
Status:OK	0000

## 7.4 AUTOMATIC DEFROST, DESINFECTATION AND POWER SAVING SETTINGS

Press  to open the Settings menu.

>	Chamber temp	-20 °C
	Quickfreeze	Off
	UV disinfection	
	Light	Auto

Select Program settings and press  to open the menu for setting automatic defrost and power saving times.

	TIME	TUE	13:05:05
	Language		English
	Display version		
>	Program settings		5 µm

Enter PIN Code 5792.

PIN Code is usually restricted to service technicians or instrument administrators

Enter PIN	
0000	

Select defrosting programs 1 to 3 and set a time for the automatic defrosting programme.  
(e.g. each day at 12:00 h and at 23:00 h in this example)

>	Defr. Start 1	12:00
	Defr. Start 2	23:00
	Defr. Start 3	_::_
	Disinf. Req.	_::_

Select temperature increase start and set a starting time for the automatic power saving mode.  
(e.g. start at 21:00 h in this example)

	Disinf. delay	10 h
>	Incr. start	21:00
	Incr. end	04:00
	Incr. days	

Select temperature increase end and set a ending time for the automatic power saving mode.  
(e.g. end at 04:00 h in this example)

	Disinf. delay	10 h
	Incr. start	21:00
>	Incr. end	04:00
	Incr. days	____ 6 7

Select temperature increase days and set the days at that the automatic power saving mode will be active for 24 hours.

(e.g. Saturdays and Sundays in this example)

Disinf. delay	10 h
Incr. start	21:00
Incr. end	04:00
> Incr. days	----- 6 7

1-Monday 2-Tuesday 3-Wednesday 4-Thursday 5-Friday 6-Saturday 7-Sunday

### Settings for disinfection parameters:

The disinfection cycle works in a semi-automated way.

First select a time when the system will ask for a disinfection cycle.

(e.g. at 12:00 h the instrument will ask for a disinfection cycle).

> Disinfec. Req.	12:00
Disin. Days	1 2 _ _ _ _
Disin. Delay	10 h
Incr. start	21:00

Select the days in which a disinfection cycle can be activated for the whole day.

(e.g. Monday and Tuesday in this example)

Disinfec. Req.	12:00
> Disin. Days	1 2 _ _ _ _
Disin. Delay	10 h
Incr. start	21:00

1-Monday 2-Tuesday 3-Wednesday 4-Thursday 5-Friday 6-Saturday 7-Sunday

Select the delay time at which the disinfection cycle will be activated.



(e.g. 10 hours)

After confirmation the disinfection cycle will start at 10 p.m.

Disinfec. Req.	12:00
Disin. Days	1 2 _ _ _ _
> Disin. Delay	10 h
Incr. start	21:00

## 7.5 List of available software settings (1<sup>st</sup> level)

<b>Chamber temperature</b>	-35 °C to 0 °C
<b>Object cooling</b> (optional)	ON / OFF  If the instrument is equipped with the optional object cooling system, its function can be activated or deactivated.
<b>Object temperature</b> (optional)	-50 °C to 0 °C  If the instrument is equipped with the optional object cooling system, its function can be activated or deactivated.
<b>Quick-freeze</b> (optional)	ON / OFF  If the instrument is equipped with the optional fast cooling peltier system, its function can be activated or deactivated.  The default setting for automatic deactivation of the quick freeze is set to 30 minutes. The timer for automatic deactivation can be set by an authorized service technician.
<b>UV disinfection</b> (optional)	ON /OFF  If the instrument is equipped with the optional UV-C disinfection system, its function can be activated or deactivated.  The default setting for automatic deactivation is set to 30 minutes. The timer can be set by an authorized service technician.
<b>Light</b>	ON / OFF / AUTO  The light can be set on or off. If AUTO has been selected, the light will switch off after the time being set under Light duration.

<b>Light duration</b>	0 - 99 minutes
<b>Chamber Increase</b>	For power saving, a higher temperature can be set for defined times and/or days.
<b>Retraction</b>	0 - 200 µm
<b>Start defrost</b>	Activate A manual defrost procedure is activated.
<b>Trim latching</b>	ON/OFF If Trim latching mode is activated, trimming function is activated and deactivated by pressing  once. If Trim latching mode is deactivated, trimming function is activated by continuously pressing  .
<b>Contrast</b>	Display contrast
<b>Time</b>	Day and Time
<b>Language</b>	A language can be selected out of a list of available languages.
<b>Display version</b>	Display of software version.
<b>Program settings</b>	Upon selecting Program settings the automatic defrost and power saving settings can be changed.

## 8. OPERATION OF MICROTOME

### 8.1 INSERTION AND ORIENTATION OF KNIFE

Activate hand wheel lock.

Loosen the knife fixation by turning two screws in the front of the knife holder counter clockwise

Remove / Insert knife

Tighten the knife fixation by turning the two screws in the front of the knife holder clockwise.

Adjust knife height by turning the wheels on the left and right side of the knife holder base.

Release hand wheel lock for cutting.

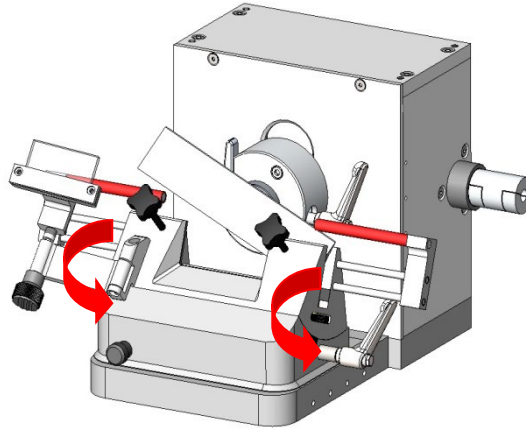

Loosening of knife fixation and insertion of new knife.

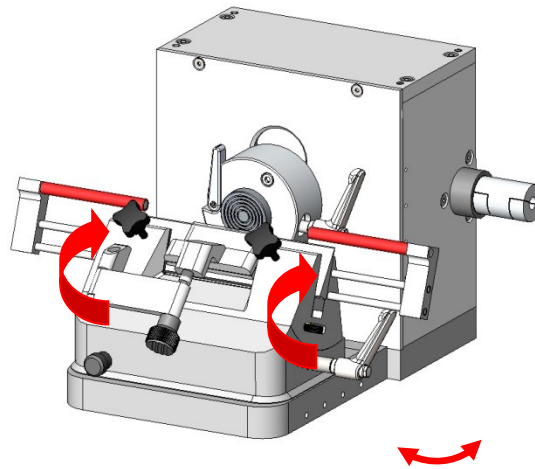

Fixation and height adjustment of knife.

## 8.2 INSERTION AND ORIENTATION OF DISPOSABLE BLADE

Activate hand wheel lock.

Remove finger protection.

Loosen the blade fixation by turning the right lever counter clockwise.

Remove/Insert blade from one side.

Tighten the blade fixation by turning the right lever clockwise.

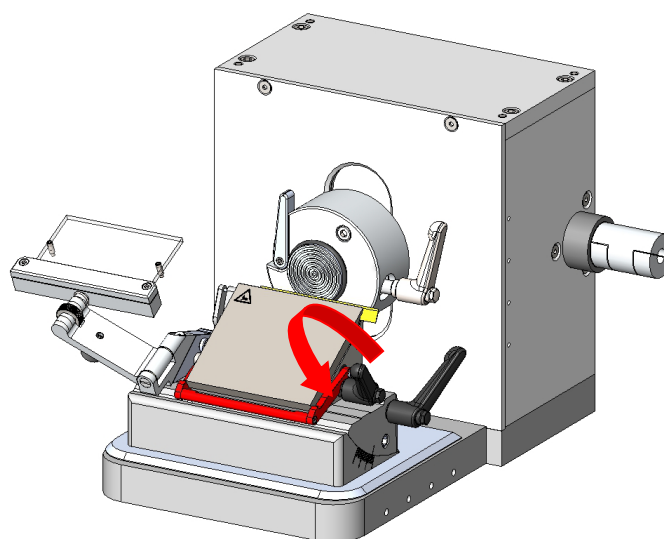

Loosening of blade fixation and insertion of new blade.

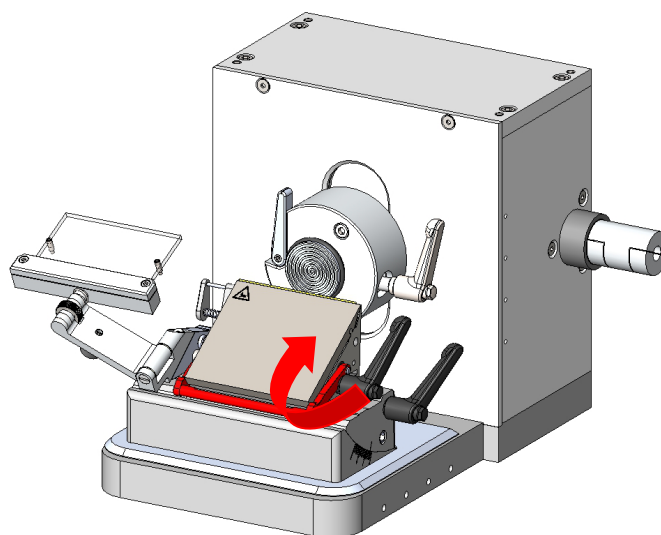

Fixation of blade.

For adjusting the cutting angle of the blade, loosen the blade holder fixation by turning the right lever on the blade holder base counter clockwise.

Set new angle for cutting by turning the knob in the front of the blade holder or by manual tilting the blade holder. A tilt towards the object holder increases the cutting angle (clockwise turn of the knob), a tilt away from the object holder decreases the cutting angle (counter clockwise turn of the knob).

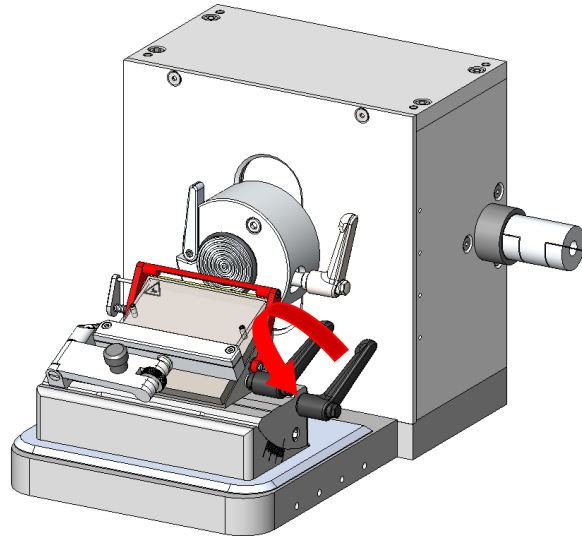

Loosening of blade holder fixation and adjusting new cutting angle (increased cutting angle).

Tighten the blade holder fixation by turning the right lever on the blade holder base clockwise.

Release hand wheel lock for cutting.

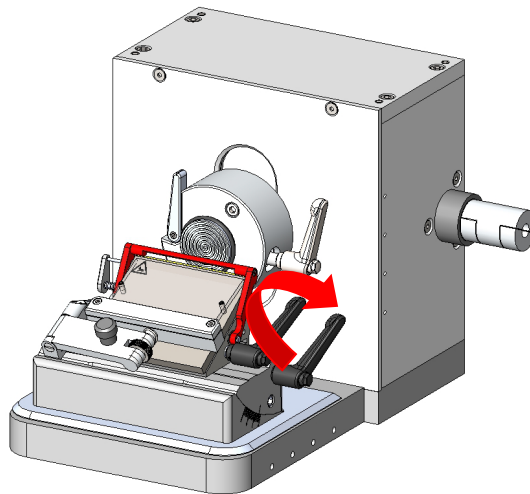

Fixation of blade holder with increased cutting angle.



### 8.3 SPECIMEN MOUNTING

The instrument is equipped with 24 freezing positions. The temperature is approx. 10 °C lower than the actual cryochamber temperature.

In order to prepare a specimen for sectioning, place the specimen holder on a freeze point, add some drops of embedding medium (e.g.GSV1) on the holder and carefully press the object on top.

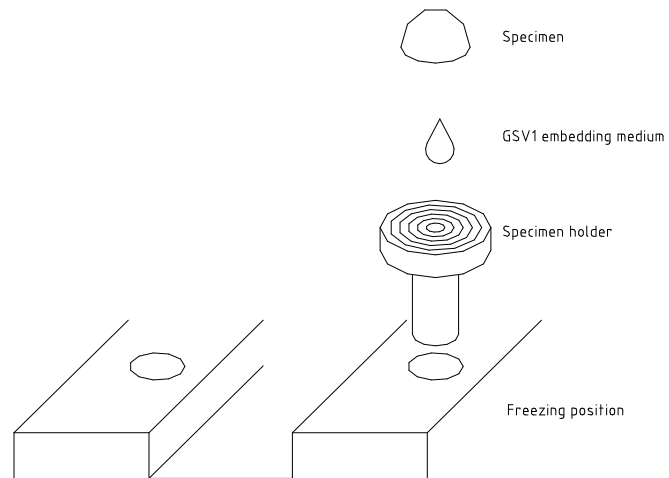

Wait until the object is frozen (mat surface or pressure).

### 8.4 INSERTION OF OBJECT HOLDER

1. Turn hand wheel to its highest position and activate the hand wheel stop.
2. Release the object holder fixation by turning the fixation lever counter clockwise.
3. Remove/Insert object holder.
4. Tighten the object holder by turning the fixation lever clockwise.

The fixation lever is limited in the range of rotation downwards due to risk of collision.

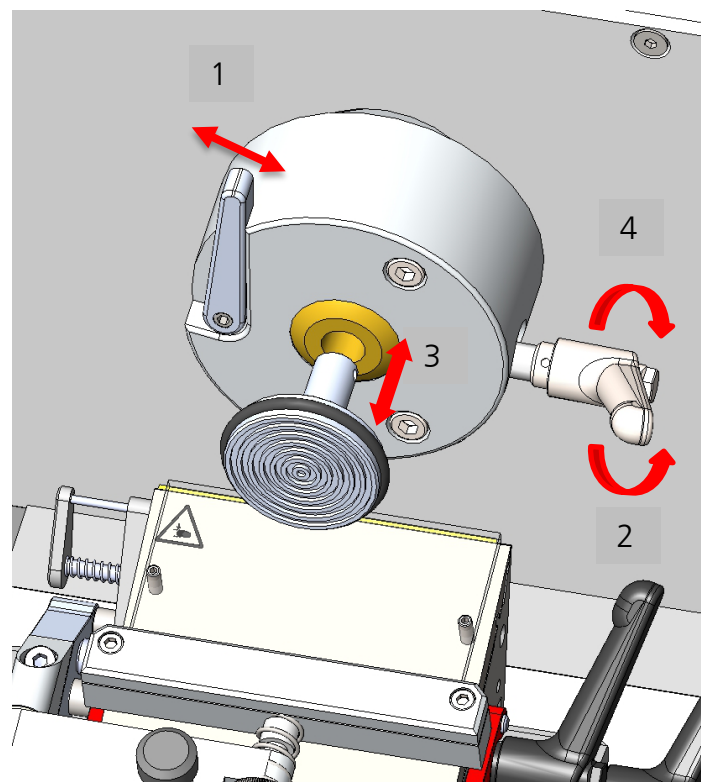

Release of object holder fixation; removal and/or insertion of object holder.

## 8.5 SPECIMEN ORIENTATION ADJUSTMENT

Turn hand wheel to its highest position and activate the hand wheel lock.

1. For a new sample orientation, loosen the fixation lever on the left side of the sample holder counterclockwise.
2. To adjust the orientation, swing the right orientation screw.

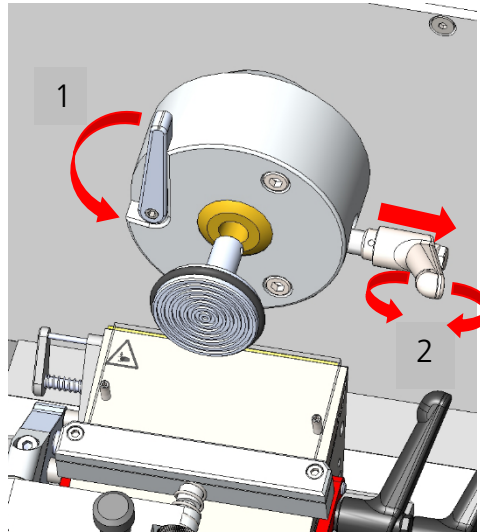

Release the sample orientation and orientation of the sample.

Fix the sample orientation by turning the fixation lever on the left side of the sample holder clockwise.

Release the handwheel lock to cut the samples.

The object orientation has a zero point notch and automatically locks the sample holder parallel to the microtome.

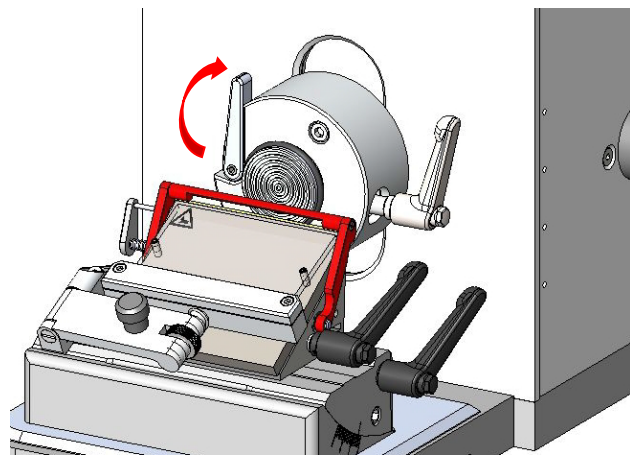

Fix the sample orientation.

## 8.6 FAST APPROACH TO SPECIMEN

Press  to move the knife holder base towards the sample.

Press  to move the knife holder away from the sample.

## 8.7 SLOW APPROACH TO SPECIMEN

Press  to move the knife holder base slowly towards the sample.

## 8.8 THICKNESS ADJUSTMENT FOR TRIMMING

To change the trimming settings, press  continuously and press  or  to increase or decrease the value.

## 8.9 THICKNESS ADJUSTMENT FOR CUT

To change the cutting thickness, press  or  to increase or decrease the value.

## 8.10 TRIMMING OF SPECIMEN

Insert object holder.

Orientate specimen as desired.

Deactivate the hand wheel stop.

Release finger protection.

If Trim latching mode is activated, trimming function is activated and deactivated by pressing  once. Activation of trim latching is displayed as illustrated.

TUE 13:05:05	
--TRIM--	Trim: 19µm
Cha: -20 °C (-22)	QF: 0
Status:OK	0000

If Trim latching mode is deactivated, trimming function is activated by continuously pressing .

Turn hand wheel evenly clockwise

## 8.11 MANUAL CUTTING

Deactivate the hand wheel stop.

Release the finger protection.

Turn hand wheel evenly clockwise.

A counter clockwise movement of the hand wheel will also result in cutting and incremental advance of the specimen.

Approach specimen either by trimming or slow approach.

Set the required section thickness. Change entries by pressing  $\boxed{+}$  or  $\boxed{-}$ . The selected section thickness is indicated in the display. (e.g. 7  $\mu\text{m}$  in this example)

TUE 13:05:05	
CUT: 7 $\mu\text{m}$	Trim: 19 $\mu\text{m}$
Cha: -20 °C (-22)	QF: 0
Status:OK	0000

Turn hand wheel until some even sections have been obtained.

Clean the microtome knife or disposable blade (always away from the cutting edge) with a cold brush.

Position anti-roll plate onto the microtome knife or disposable blade and cut. If necessary readjust the height of the guide plate.

Leave hand wheel with handle at its lowest point (specimen holder underneath the microtome knife or disposable blade).

Transfer the section onto a slide.



Leave brush always in the chamber to keep it cold.



## 8.12 MOTOR SETTING

For setting of vertical motor speeds, press  to activate the motor.



TUE 13:05:05	
CUT: 7 $\mu$ m	Trim:
Cha: -20 °C (-22)	QF: 0
Status:OK	0000

The display will indicate the speed for the downward (↓) and the upward (↑) movement of the specimen.

TUE 13:05:05	
CUT: 7 $\mu$ m	Trim: 19 $\mu$ m
Cha: -20 °C (-22)	QF: 0
↓ 40 mm/s	↑ 125 mm/s

To adjust the setting for the downward movement, press  and simultaneously  or  to increase or decrease the speed setting.

TUE 13:05:05	
CUT: 7 $\mu$ m	Trim: 19 $\mu$ m
Cha: -20 °C (-22)	QF: 0
↓ 35 mm/s	↑ 125 mm/s

To adjust the setting for the upward movement, press  and simultaneously  or  to increase or decrease the speed setting.



TUE 13:05:05	
CUT: 7 $\mu$ m	Trim: 19 $\mu$ m
Cha: -20 °C (-22)	QF: 0
↓ 40 mm/s	↑ 140 mm/s

### 8.13 CONTINUOUS CUTTING

Release hand wheel stop.

For continuous cutting, press  to activate the motor.

The LED on the left side of the button is illuminated, if the motor is activated.

Select the stop position of the specimen head after cutting. If  is selected, the specimen head will stop at the highest position, if  is selected, the specimen head will stop at the lowest position when stopped.

Press  to start the motor. The footswitch can be used alternatively.

The LED on the left side of the button is illuminated, if the motor is running.

Press  to stop the motor. The footswitch can be used alternatively.



As long as the motor is activated, manual cutting is not possible.



Do not start motor functions with activated hand wheel lock ! Failure to comply may result in severe damage to the instrument.

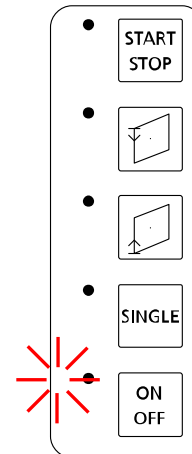

Activated cutting motor is shown by illumination of the LED as displayed above.

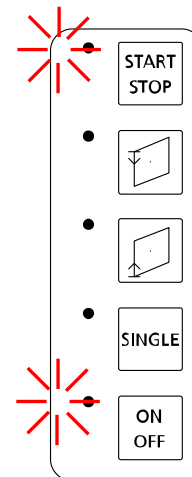

Activation and running of cutting motor is shown by illumination of the LEDs as displayed above.

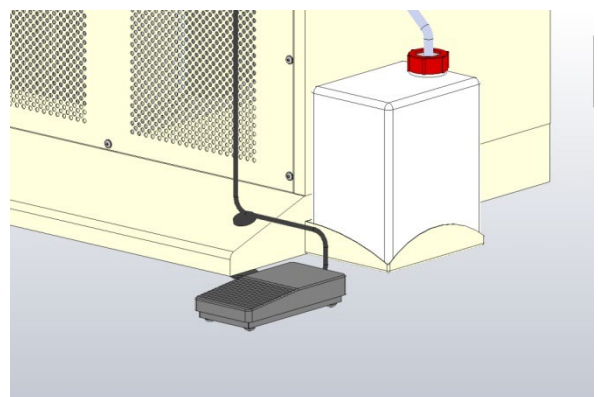



Foot switch for control of the cutting motor.

For trimming of specimen, select the thickness as described in section 8.8 (THICKNESS ADJUSTMENT FOR TRIMMING).

If Trim latching mode is activated, trimming function is activated and deactivated by pressing  once. Activation of the trimming function is displayed as illustrated.

Activation of trim latching mode is described in section 7.2.

If Trim latching mode is deactivated, trimming function is activated by continuously pressing . Activation of trimming function is displayed as illustrated above.

Optionally press  continuously to increase the cutting speed to the value set for the upward movement (see 8.12). If  is released, the instrument will return to its original cutting speed.

TUE 13:05:05	
--TRIM--	Trim: 19µm
Cha: -20 °C (-22)	QF: 0
↓ 40 mm/s	↑ 125 mm/s

Display with activated trimming function

TUE 13:05:05	
CUT: 7 µm	Trim: 19µm
Cha: -20 °C (-22)	QF: 0
↓ 40 mm/s	↑ 125 mm/s



Display with deactivated trimming function.

## 8.14 SINGLE CUTTING

Release hand wheel stop.

For single cutting, press  to activate the motor and press  to activate the single cut mode.

The LED on the left side of the buttons is illuminated, if the motor is activated and the single mode is activated.

Select the stop position of the specimen head after cutting. If  is selected, the specimen head will stop at the highest position, if  is selected, the specimen head will stop at the lowest position.

Press  to start the motor. The footswitch can be used alternatively.

The motor will automatically stop after one cut.



As long as the motor is activated, manual cutting is not possible.



Do not start motor functions with activated hand wheel lock ! Failure to comply may result in severe damage to the instrument.

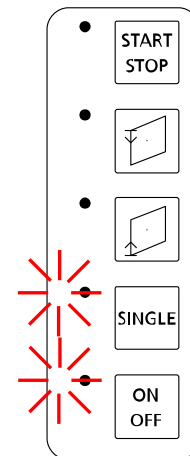

Activation and running of cutting motor in single cutting mode is shown by illumination of the LEDs as displayed above.

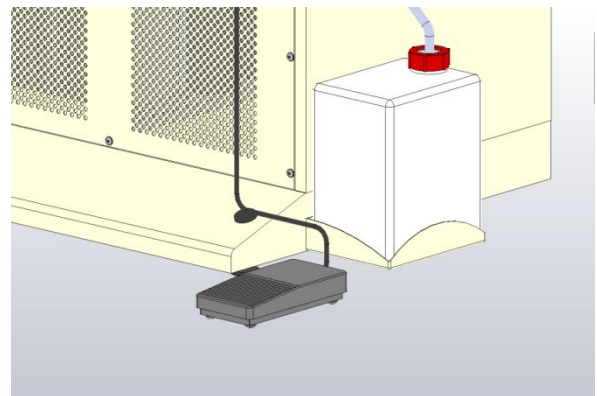

Foot switch for control of the cutting motor.



## 8.15 ANTI-ROLL PLATE

Each instrument is equipped with an anti-roll plate.

To adjust the horizontal position of the anti-roll plate turn the wheel to the left (towards blade) or right (away from blade).

For pick up of the samples turn the anti-roll plate side wards with the help of the knob.

In this case, make sure that the anti-roll-plate is folded into the horizontal position when it is unfolded in order to prevent a one-sided warm-up.

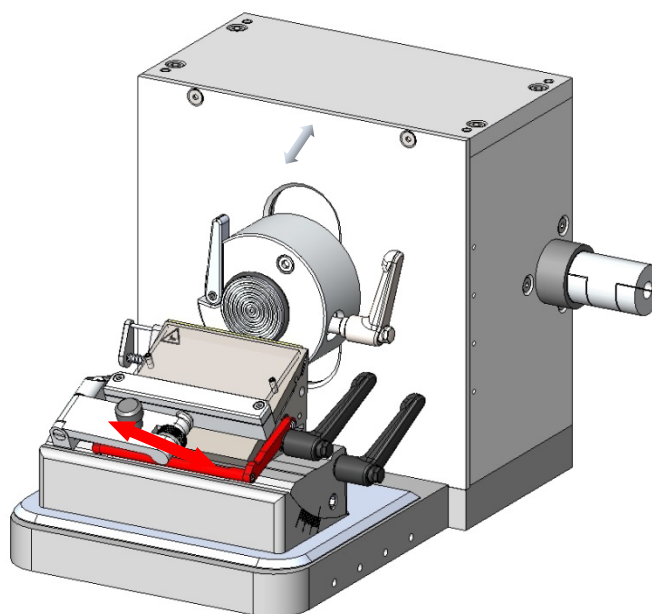

Horizontal adjustment of anti-roll plate



For height adjustment of the anti-roll-plate it is recommended to adjust the correct height during cutting.

## 8.16 TIPS AND TRICKS

It is common knowledge that the temperature of the cryostat plays an important role in the quality of the tissue sections obtained. Each type of tissue needs a different temperature as shown in the following list. The temperature ranges indicated in the table below are approximate values and may require adjustments for individual tissues.

<b>Type of Tissue</b>	<b>Recommended temperature range at the knife or blade edge [°C]</b>
Bone marrow	-16 to -25
Brain	-7 to -10
Breast with fat	-25 to -30
Breast without fat	-16 to -20
Cartilage	-13 to -20
Fat	-30 to -40
Heart	-20 to -25
Intestinal	-13 to -20
Kidney	-13 to -20
Larynx	-13 to -16
Lip	-10 to -20
Liver	-7 to -13
Lung	-13 to -20
Lymph-Node	-13 to -20
Lymphatic	-13 to -20
Lymphoid	-13 to -20
Muscle	-13 to -20
Nose	-13 to -20
Rectal	-13 to -20
Scrapings	-16 to -25
Skin with fat	-16 to -25
Skin without fat	-10 to -16
Spleen	-7 to -10
Testicle	-10 to -13
Tongue	-13 to -20
Uterine-Curettings	-7 to -10

## 9. OPERATION OF CRYOSTAT

### 9.1 UV-C DISINFECTION [only applicable to instruments equipped with this feature]

UV-C radiation at 254 nm has an intense germicidal effect. Microorganisms, such as viruses, bacteria, fungi and yeasts are effectively destroyed in the area accessible to UV light without the addition of chemicals.

The cryostat MNT can be equipped with an UV-C light source that can either be automatically activated (see section 7.3) or manually activated.

The default setting for the UV-C light duration and the automatic deactivation is set to 30 minutes. The timer can be set by an authorized service technician.



For safety reasons UV-C light will be deactivated upon opening of the lid of the cryochamber. The UV-C disinfection will be aborted and has to be activated again for surface disinfection.

The default setting for automatic deactivation is set to 30 minutes. The timer can be set by an authorized service technician.

#### 9.1.1 INSTALLATION INSTRUCTIONS FOR UV LAMP - CRYOSTAT

Please follow the respective steps and pay attention to the relevant instructions.

Touch the UV lamp never directly on the glass, since this reduces the durability may be

Picture 1:



Picture 2:



Picture 3:



Slide the UV lamp as shown into the glass bulb. Keep 2cm space before the endposition will be reached, this place will be needed to connect the UV Lamp with the connecting plug. (Pic. 2 & 3).

Picture 4:



Picture 5:



The connector can be plugged into two directions of polarity, a switch is excluded.

Picture 6:

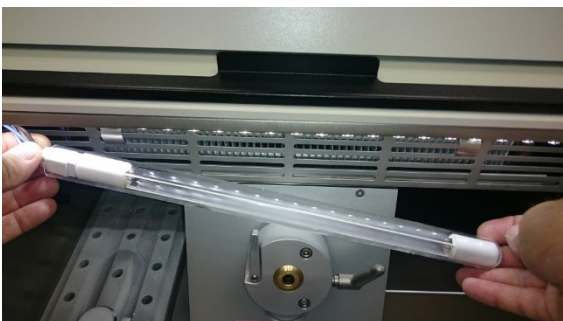

Picture 7:



Once the plug is connected to the UV- Lamp, the final step can be done now and the UV-Lamp unit can clip into the retaining clips.

## 9.2 QUICK FREEZE POSITION [only applicable to instruments equipped with this feature]

For convenience of the user, the cryostat MNT can be equipped with a quick freeze shelf with two positions located in the object freezing shelf. Upon activation the installed peltier element will cool down the two quick freeze position to approximately -55 °C.

The quick freeze shelf can be activated as described in section 7.2.



The automatic shutdown of the fast freezing positions is set to 30 minutes. The shutdown interval can be changed by an authorized service technician.

## 9.3 HEAT EXTRACTOR

For a more rapid freezing process with improved structural preservation of tissues and a flattened block surface, the instrument is equipped with a heat extractor.

Apply the heat extractor on top of the specimen during the freezing process.



Heat extractor



Use of the heat extractor can lead to changed orientation of the specimen in the frozen block, especially for smaller samples. If precise orientation of the specimen is required, the freezing procedure should be performed without the heat extractor.

## 9.4 AUTOMATIC/MANUAL DEFROST

For an optimal effect of the cooling machine, a low thermal resistance at the cooling ribs is necessary. Frequent use of the cooling machine condenses moisture on these cooling ribs and increases the thermal resistance. Therefore, the device, in particular the cooling ribs, is automatically defrosted.

During an automatic defrost (programmed for every midnight) or an manual activated defrost (possible at every time) hot gas from the cooling system is pressed through the evaporator. All ice which has been built up is melted, the water drops into the condensate bottle.

The defrosting process ends at a temperature of 20 °C on the evaporator. The chamber temperature remains in the minus range, so that samples which are stored there do not thaw.



The default setting for automatic defrost is set to 00:00 o'clock (midnight) each day. For changing the settings, please refer to section 7.3.

Always keep the front cover closed during the process.

## 9.5 SHUTDOWN AND CLEANING THE DEVICE

It is highly recommended to defrost the instrument at least every 6 months. If the instrument is used regularly in warm tropical climate a more frequent complete defrost might be necessary. The unit should be defrost for a minimum period of 48 h, better over the weekend.

Turn hand wheel to its highest position and activate the hand wheel stop.

Remove samples and tools from the cryochamber.

Switch off the instrument. Be sure to open the front window and leave it open until it is switched back on.

Before restarting, the microtome and the cooling chamber must be completely dry in order to avoid a decision.

Switch on the instrument.



Before starting a complete defrost of the instrument, assure that all samples have been removed from the cryochamber.

Before switching on the instrument ensure that the instrument is completely dry, otherwise ice built up can damage mechanical parts.

## 9.6 EMPTYING THE CONDENSATE BOTTLE

The unit is equipped with a condensate bottle for defrosting water. The filling level of the collecting container is checked with a fill level sensor. As soon as "full container" is displayed in the display, the collecting container must be emptied in order to avoid overfilling.



The contents of the condensate bottle should be disposed according to laboratory regulations.



To reduce the risk of contamination and infection, after emptying, is recommended to fill a disinfectant concentrate into the condensate bottle..

## 10. CLEANING AND MAINTENANCE

### 10.1 CLEANING

The recommended frequency of cleaning of the cryostat chamber depends on how frequently the instrument is used.



Wear protective clothing and disposable gloves according to Good Laboratory Practices.

Please take note of the safety aspects of the instrument.

Do not use acetone or xylene for cleaning the unit. Only use alcoholic media.

Never spray or use cleaning medium directly onto the touch panels.

### 10.2 RECOMMENDED MAINTENANCE AND SERVICE SCHEDULE

**Daily** Remove frozen section waste from the cryostat chamber after every day of usage.

Disinfection if necessary.

**Weekly** Cleaning of blade holder (see section 10.3).

Cleaning of window.

**Monthly** Check of temperature sensor in cryochamber.

Cleaning of cryostat ventilation (see section 10.4).

**Yearly** Complete Service (performed by authorized Slee service technician)

- check of all functions
- complete defrost
- removing of microtome
- oiling of movable parts
- check of cooling system
- check of driving system
- complete disinfection / cleaning / drying



### 10.3 CLEANING OF DISPOSABLE BLADE HOLDER

Turn the handwheel to the highest position and operate the handwheel lock.

Loosen the blade by turning the lever counterclockwise.

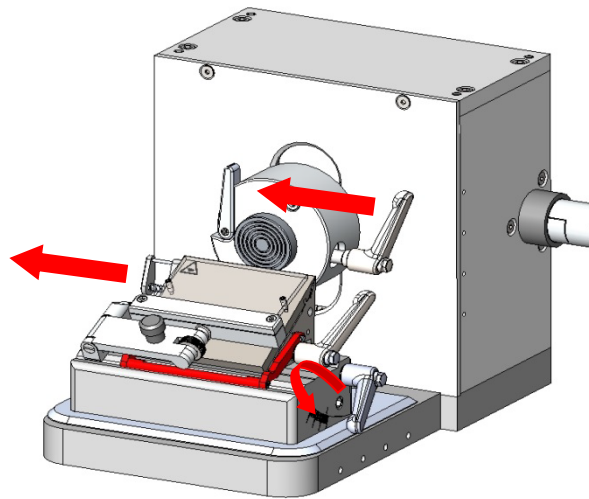

Pull out the lever and release the upper blade holder.

After removing the blade, pull out the lever, remove the pressure plate and clean the blade holder with a brush or cloth.

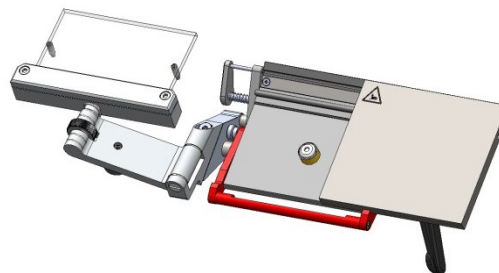

Cleaning of disposable blade holder.

Reassemble the pressure plate and the lever and loosen the locking device for cutting.

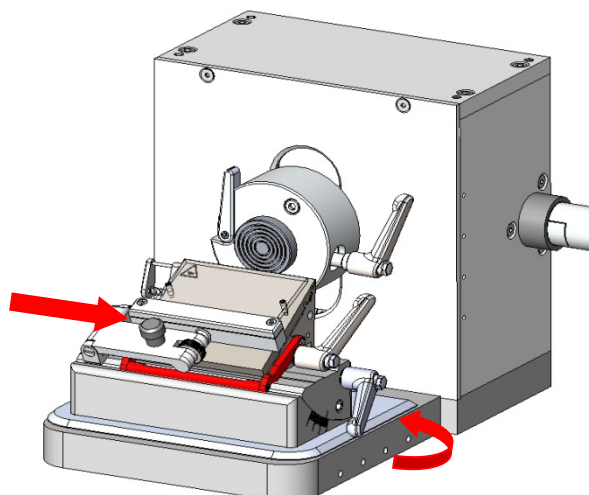

Assemble the blade holder.

## 10.4 CLEANING OF CRYOSTAT VENTILATION

During usage of the instrument dust will deposit on the ventilation of the cooling unit. This can negatively affect the cooling performance of the instrument.

A cleaning of the cryostat ventilation is recommended monthly.

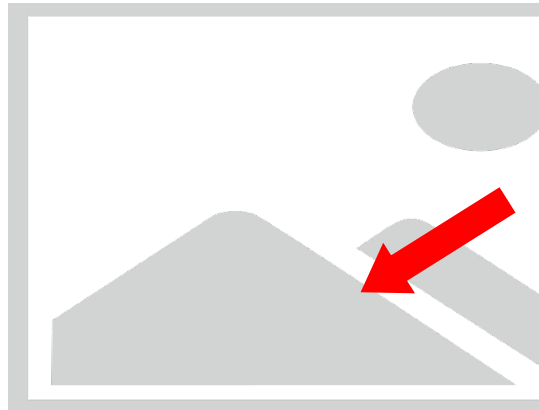

## 11. SERVICE

Internal components should only be serviced by technicians authorized by SLEE medical GmbH.

If technical service or spare parts are necessary, please contact your local SLEE medical GmbH distributor. Please have the following information available:

- Complete contact details
- Type of instrument and serial number
- Place of instrument and name of user
- Purpose of service call
- Delivery date of the unit

If it is necessary to return the instrument, it must be cleaned and disinfected before delivery. It must be returned in its original packing.

If the instrument or parts thereof are sent back in a dirty or non-disinfected condition, SLEE medical GmbH reserves the right to return the parts to the debit of the customer.

## 12. OPTIONAL ACCESSORIES

### **Standard Knife Holder**

#10156010

### **Disposable Blade Holder (low profile)**

#10157005

### **Disposable Blade Holder (high profile)**

#10158005

### **2x Quick freezing positions**

# 10159000

### **UV disinfection**

# 10169000

### **Object Cooling**

#10164000

### **Debris extraction system**

#10167100

### **Heat extractor block**

# 31000253

### **Object holder (Ø 22 mm)**

#30000002

### **Object holder (Ø 35 mm)**

#30000000

### **Object holder (Ø 50 mm)**

#30000003

### **Cork plate (100 pcs.; Ø 20 mm)**

#30001001

### **CryoGlue embedding medium (4x 125 ml)**

#30001100

### ***clear-cut* brush**

#30001030

### **Anti-roll plate (disposable blade holder)**

#32001050

### **Anti-roll plate (standard knife holder)**

#32001049

### **Disposable blade (low profile; 50 pcs.)**

#28407000

### **Disposable blade (high profile; 50 pcs.)**

#28408000

### **Disposable blade (low profile; 50 pcs.), Plasma LPH, for hard specimen**

#28407004

### **Disposable blade (low profile; 50 pcs.), Plasma LPS, for soft specimen**

#28407005

### **Disposable blade (high profile; 50 pcs.), Plasma HPS, for soft specimen**

#28407007

### **13. WARRANTY**

SLEE medical GmbH guarantees that the product delivered has been subjected to a comprehensive quality control procedure, and that the product is faultless and complies with all technical specifications and/or agreed characteristics warranted.

SLEE medical GmbH guarantees that the instrument is manufactured under an ISO 9001:2015 and ISO 13485:2016 quality management system.

Unauthorized modification or repair by third party persons will void the warranty.

Only original SLEE medical GmbH spare parts must be used.

Guarantee claims can be put forward only if the instrument is used according to this manual and for the purpose described.

Mistakes and errors which occur because of improper use cannot be accepted.

### **14. DISPOSAL**

The instrument or parts of the instrument must be disposed of according to existing local applicable regulations.

**Notes**

**Notes**





SLEE medical GmbH · Am Neuberg 14  
55268 Nieder-Olm · Germany  
[www.slee.de](http://www.slee.de)

T: +49 (0) 6136 76997-0  
E: [mail@slee.de](mailto:mail@slee.de)



[www.slee.de](http://www.slee.de)



YouTube



LinkedIn



Instagram